

devolo

MultiNode LAN



USER MANUAL

© 2025 devolo solutions GmbH Aachen (Germany)

The reproduction and distribution of the documentation and software supplied with this product and the use of its contents is subject to written authorization from devolo. We reserve the right to make any alterations that arise as the result of technical development.

Trademarks

Android™ is a registered trademark of Open Handset Alliance.

Linux® is a registered trademark of Linus Torvalds.

Ubuntu® is a registered trademark of Canonical Ltd.

Mac® and MacOS® are registered trademarks of Apple Computer, Inc.

Windows® and Microsoft® are registered trademarks of Microsoft, Corp.

devolo and the devolo logo are registered trademarks of devolo solutions GmbH.

The firmware package from devolo contains files which are covered by different licenses, in particular under devolo proprietary license and under open source license (GNU General Public License, GNU Lesser General Public License or FreeBSD License). The source code which is available for Open Source distribution can be requested in writing from gpl@devolo.de.

All other names mentioned may be trademarks or registered trademarks of their respective owners. Subject to change without notice. No liability for technical errors or omissions.

devolo solutions GmbH

Charlottenburger Allee 67

52068 Aachen Germany

www.devolo.global

1. Introduction	4
1.1 Getting started	4
1.1.1 Who should read this manual	4
1.1.2 What you need	4
1.1.3 Overview	4
1.2 Product overview	4
1.2.1 How MultiNode network works	4
1.2.2 Product documentation	5
1.2.3 Migrating older firmware versions	5
1.3 Safety and compliance	5
1.3.1 Intended use	5
1.3.2 Safety	5
1.3.3 CE Conformity	7
1.3.4 UKCA Conformity	7
1.4 Glossary of MultiNode terms	7
2. Device specification	8
2.1 Specification	8
2.2 Mains interface	8
2.3 Ethernet interface	9
2.4 LEDs	9
2.5 Factory reset button	10
2.6 Reboot button	10
3. Network Architecture	11
3.1 Before installation	11
3.2 Power supply considerations	11
3.3 Distance guidelines	11
3.3.1 Per-hop distance recommendations	11
3.4 Network architecture decisions	12
3.4.1 Single vs. multiple mains circuits	12
3.4.2 Network topology options	12
3.5 Master node placement	12
3.6 Adding repeaters	13
3.7 Planning load management	13
3.7.1 Options for load management	13
3.8 Common installation scenarios	13
3.8.1 Outdoor car parks	13
3.8.2 Multi-floor car parks	14
3.9 Reference installations	15
3.9.1 1: Single-circuit setup	15

3.9.2 2: Multiple-circuit setup	16
3.9.3 3: Multiple MultiNode networks	17
3.9.4 4: Centralized load management	18
3.9.5 5: Master/slave charging stations	19
3.9.6 6: Mobile radio gateway	20
4. Electrical installation	21
4.1 Safety instructions	21
4.2 Instructions for electrical installation	22
5. Web interface	24
5.1 Web interface	24
5.2 Accessing the web interface	26
5.2.1 Initial access to the web interface	26
5.2.2 Check your firmware version	26
5.3 Setting up a new MultiNode network	27
5.4 Extending an existing MultiNode network	31
5.4.1 Adding one or few devices	31
5.4.2 Adding several devices	33
5.4.3 Verification	34
5.5 Overview	36
5.5.1 Table & topology views	37
5.6 Powerline	39
5.7 Network Manager	41
5.7.1 Network Manager → Settings	41
5.7.2 Network Manager → Synchronisation	42
5.7.3 Network Manager → Firmware	43
5.8 LAN	45
5.9 System	46
5.9.1 System → Status	46
5.9.2 System → Management	47
5.9.3 System → Certificate	50
5.9.4 System → Configuration	51
5.9.5 System → Firmware	52
6. Support & Warranty	53
6.1 Contact us	53
6.2 Warranty	53

1. Introduction

MultiNode LAN 4TE is a compact DIN-rail device that sends data over existing power lines. It is built to handle demanding environments and can scale easily, making it a strong fit for large sites such as EV charging networks.

This manual helps you plan, install, configure, and maintain a MultiNode LAN network. It covers the MultiNode device, the MultiNode network setup, the electrical installation, and the built-in web interface.

1.1 Getting started

1.1.1 Who should read this manual

- Qualified electricians: mounting and wiring
- Network technicians and admins: network design and web interface configuration

1.1.2 What you need

- Data sheet (technical specifications)
- Laptop with a LAN port to connect to a MultiNode LAN 4TE
- LAN cable of sufficient length

1.1.3 Overview

The user manual is structured as follows:

- [This chapter](#) lists the supplied documents, intended use, safety information, symbols, CE and UKCA information, and a glossary of MultiNode terms.
- Chapter [MultiNode LAN](#) provides a specification of MultiNode LAN 4TE.
- Chapter [Architecture](#) shows common network setups in EV charging and how MultiNode LAN 4TE products fit into them.
- Chapter [Electrical installation](#) explains the mounting and physical installation steps.
- Chapter [Web Interface](#) gives an overview of the built-in web-interface of MultiNode LAN 4TE, with instructions for setting up the MultiNode network.
- In Chapter [Support, Warranty & Legal Notice](#), you'll find contact details, warranty terms, and legal notices.

1.2 Product overview

1.2.1 How MultiNode network works

- One device is the master; all others are regular nodes (leaf or repeater).

- Regular nodes communicate with the master over PLC.
- Peer-to-peer communication between regular nodes is isolated, i.e., regular nodes can only communicate with the master.
- The web interface of the master node can be used to setup and configure the network.

1.2.2 Product documentation

MultiNode LAN 4TE includes the following supporting documents:

- Safety & service flyer: General safety and service information
- Data sheet: Technical specifications
- User manual (this document)

1.2.3 Migrating older firmware versions

Update to the latest firmware



This user manual assumes your MultiNode LAN 4TEs are on the latest firmware (7.16.7.35 • 2025-11-13). To identify the firmware version of your device, connect a laptop to the device via Ethernet cable and [check the firmware version](#) on the device's web interface.

If your MultiNode LAN 4TEs run a firmware version older than 7.16.5.31, we offer three ways to update them to the latest firmware:

1. **Update individually** by using the built-in web interface of each device; see [instructions](#).
2. **Update all devices** at once via the Firmware Migrator tool available on the [product website](#).
3. **Let us update the devices** for you: If your devices have internet access, send their serial numbers to support@devolo.de. Our support team will initiate the update remotely.

1.3 Safety and compliance

1.3.1 Intended use

MultiNode LAN 4TE is a fixed-installation device of overvoltage category 3. It communicates via powerline communication (PLC) over low-voltage mains. The unit is designed for water-protected environments and must be mounted on a DIN-rail within touch-protected or access-controlled areas.

Use the MultiNode LAN 4TE as instructed to prevent damage and injury.

1.3.2 Safety

Read and understand [all safety and operating instructions](#) before first use.

About the safety & service flyer

The safety & service flyer provides general product, conformity, and disposal information.

Documentation & downloads



A printed safety & service flyer is included with each product; this manual is provided digitally. All product descriptions are available at www.devolo.global/support/download/download/multinode-lan.

Callouts

This manual uses four standard callouts with icons. These examples show how they look and what they mean.



Electrical hazard

Hazardous electrical voltage which if not avoided can result in serious injury or death.



Qualified electrician required

Installation steps that must be performed by a qualified electrician.



Warning

An important notice to prevent potential injury or equipment damage.



Info

Helpful background information and configuration tips.



Success

Indicates that an action completed successfully.

1.3.3 CE Conformity



The MultiNode LAN is CE compliant. Download the complete [CE declaration](#).

1.3.4 UKCA Conformity



The MultiNode LAN is UKCA compliant. Download the complete [UKCA declaration](#).

1.4 Glossary of MultiNode terms

PLC (Powerline Communication): A technology that transmits data signals over existing electrical power lines by modulating high-frequency carrier waves onto the low-frequency AC power signal.

MultiNode LAN network: A network built with MultiNode devices.

Node: A device that's part of the MultiNode network.

Master node: The main controller of the MultiNode network. Only one node in the network can be the master.

Regular node: Any node that can be managed by the master node. By default, nodes are configured as regular nodes.

Seed: A number (0–59) that identifies and separates PLC networks.

2. Device specification

MultiNode LAN 4TE uses PLC to transport data over low-voltage mains cables. Its repeater function makes it well suited for large networks with up to 250 nodes.

2.1 Specification

MultiNode LAN 4TE includes:

- Five line connections (mains interface)
- One Gigabit Ethernet network interface
- Three indicator lights
 - Power
 - Network
 - Ethernet
- One reboot button
- One factory reset button

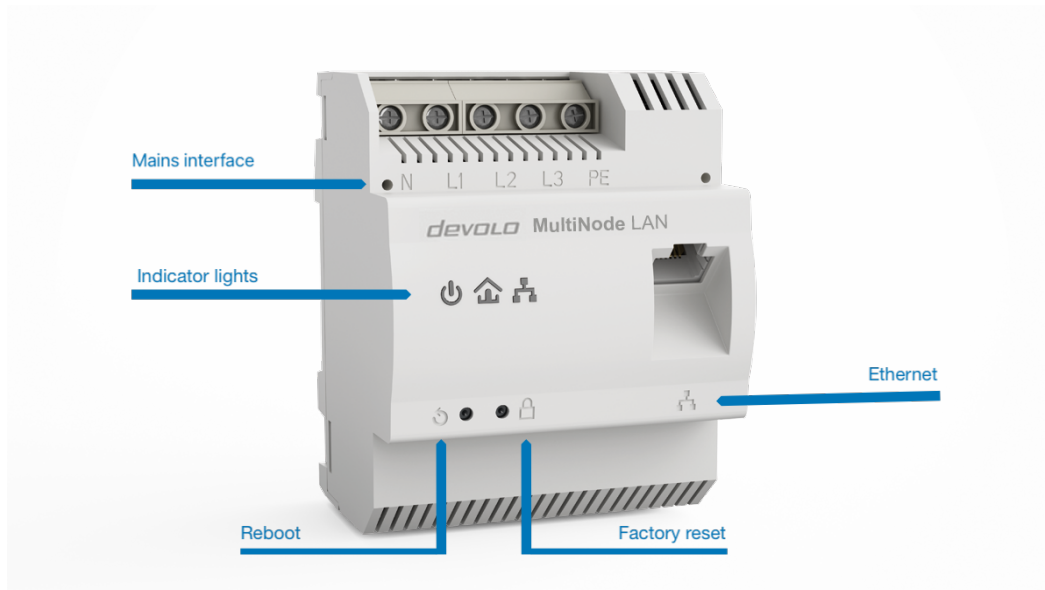

Front view of MultiNode LAN 4TE

2.2 Mains interface

The screw terminals for the primary voltage power line accept wires from 1.5 mm² to 6 mm².

Single-phase operation using L1: For single-phase operation, use the L1 terminal. L2 and L3 can remain open. The device is powered from L1/N, so using L1/N is mandatory.

Three-phase connection: Connect neutral and three external conductors to terminals N, L1, L2, and L3. The device is powered via N and L1.

Operation with or without protective earth (PE): The device can operate without connecting PE to protective earth. However, the PE terminal can enhance signal transmission over powerline.



2.3 Ethernet interface

You can use the Ethernet interface to connect:

- the master node to the local network or to an Internet gateway, or
- regular nodes to their application devices, e.g., EV charging stations.

2.4 LEDs

The integrated LEDs show the status of the MultiNode LAN 4TE by illuminating and /or flashing in two different colours:

LED	Behaviour	Status
 Power	Off	No power supply or node is defective.
	On	Node is powered.
 Network	Red for 5 s	Node booting after restart or power cycle.
	Steady red	Node not connected to a MultiNode network; ready for configuration.
	Steady white	Node connected to a MultiNode network.
	White: 1.8 s on / 0.2 s off	Node connected but configuration incomplete.
	White/red alternating, 0.3 s each	Firmware update in progress.
	Red flashing, 0.5 s on/off	Factory reset completed successfully.
 Ethernet	Steady white	Ethernet uplink active.
	Flashing white	Ethernet uplink active with data transfer.

2.5 Factory reset button



Resetting MultiNode LAN 4TE to factory defaults

To restore the device to factory default settings, press and hold the factory reset button for more than 10 seconds.

Wait until the network LED  flashes red, then add the MultiNode LAN 4TE to a network again. Note that all settings will be lost. If the node was part of a MultiNode network, it will be removed from that network.

2.6 Reboot button



Rebooting MultiNode LAN 4TE

To reboot the device, press the reboot button. The device will restart.

When the network LED  lights up red for 5 s or longer, the device is operational again.

3. Network Architecture

This chapter helps you plan and implement MultiNode network(s) in EV charging installations. Read this chapter carefully to understand how various aspects affect network performance and installation efforts so you can select an appropriate MultiNode installation for your use case.

3.1 Before installation

- Plan your power supply and circuit breaker locations.
- Consider distances between devices; keep under 50 m per hop when possible. See [Distance guidelines](#) below.
- Decide if you need one network or multiple networks.
- Plan your load management approach.

3.2 Power supply considerations

Circuit breakers: When using power rails, you need circuit breakers at each connection point. This lets you use thinner cables. You can use the same circuit breaker for both the charging station and MultiNode device, or give each one its own circuit breaker (see [Single circuit setup](#)).

Built-in power supply: MultiNode devices have integrated power supplies using L1/N terminals. Additional network components like switches and gateways need their own power supply. You can power them from the same electrical circuit or a different one (see [Single circuit setup](#)).

Independence from mains electrical power: PLC communication operates in the 2-50 MHz frequency range, which is separate from the mains electrical power.

3.3 Distance guidelines

MultiNode networks can span several hundred meters using built-in repeater functionality. Every MultiNode device automatically functions as a repeater when necessary, based on an underlying topology algorithm.

3.3.1 Per-hop distance recommendations

- Up to 50 m: Good performance
- 50-100 m: Potentially acceptable performance
- Over 100 m: Not recommended

Important: Line conditions may deteriorate over time, so plan conservatively.

3.4 Network architecture decisions

3.4.1 Single vs. multiple mains circuits

Single mains circuit (recommended): A mains circuit is any cable or power rail connected to one circuit breaker. Best performance can be expected when all devices operate on one three-phase circuit.

Multiple mains circuits: Possible but requires careful planning. The PLC signal must pass through distribution units, which can cause:

- Signal loss from multiple connection points
- Additional noise from various sources
- Impedance changes

Consider installing a repeater in the distribution unit on a separate, protected circuit (see [Multiple circuit setup](#)).

3.4.2 Network topology options

Option 1: Single large network:

- Spans multiple circuits through distribution unit
- May require longer signal paths
- Consider repeater placement (see [Multiple MultiNode networks](#))

Option 2: Multiple smaller networks

- One network per circuit or floor
- Requires Ethernet connections between networks
- Avoids distribution unit signal issues (see [Multiple MultiNode networks](#))

3.5 Master node placement

Both your electrical wiring and MultiNode network are arranged like a tree, branching out from one main point to all locations.

Your electrical system branches out from the main distribution unit. Your MultiNode network branches out from one master node to several regular nodes.

Important: The master node of the MultiNode network doesn't need to be in the distribution unit. If you can reach your network with Ethernet from another location, this is often better and avoids complications with the distribution unit.

3.6 Adding repeaters

As mentioned earlier, MultiNode devices automatically act as repeaters when needed. Supplement an existing MultiNode network with additional devices when:

- Per-hop distance is above 50 m
- Signal quality is poor
- You have long underground cables without tap-off options

Install additional tap-off boxes with circuit breakers for dedicated repeaters (see [Multiple circuit setup](#)).

3.7 Planning load management

MultiNode networks isolate regular nodes from each other — they can only communicate with the master node, not with each other. This affects how you plan load management.

3.7.1 Options for load management

Centralized management

Use a separate load management system in the building or cloud (see [Centralized load management](#)).

Master/Slave configuration

Use one charging station as the load management master (see [Master/slave charging stations](#)). Because of the network isolation, you need additional Ethernet cables so slave stations can communicate with both the master station and the gateway.

Alternative connectivity

If you use a mobile radio gateway instead of fiber, [Mobile radio gateway setup](#) shows solutions for both centralized management and Master/Slave setups. The setup may be simpler if your master charging station has built-in mobile radio or your gateway has a built-in Ethernet switch.

3.8 Common installation scenarios

3.8.1 Outdoor car parks

For outdoor installations with power rails:

1. Install distribution cabinet near power rail
2. Run fiber cable in conduit alongside mains supply cable
3. This avoids long-distance PLC connections (see [Centralized load management](#) and [Master/slave charging stations](#))

Alternative: Use mobile radio gateway to eliminate fiber requirement (see [Mobile radio gateway](#)).

3.8.2 Multi-floor car parks

Use separate networks per floor with vertical Ethernet connections between floors to avoid long PLC signal paths through distribution systems (see [Multiple MultiNode networks](#)).

3.9 Reference installations

3.9.1 1: Single-circuit setup

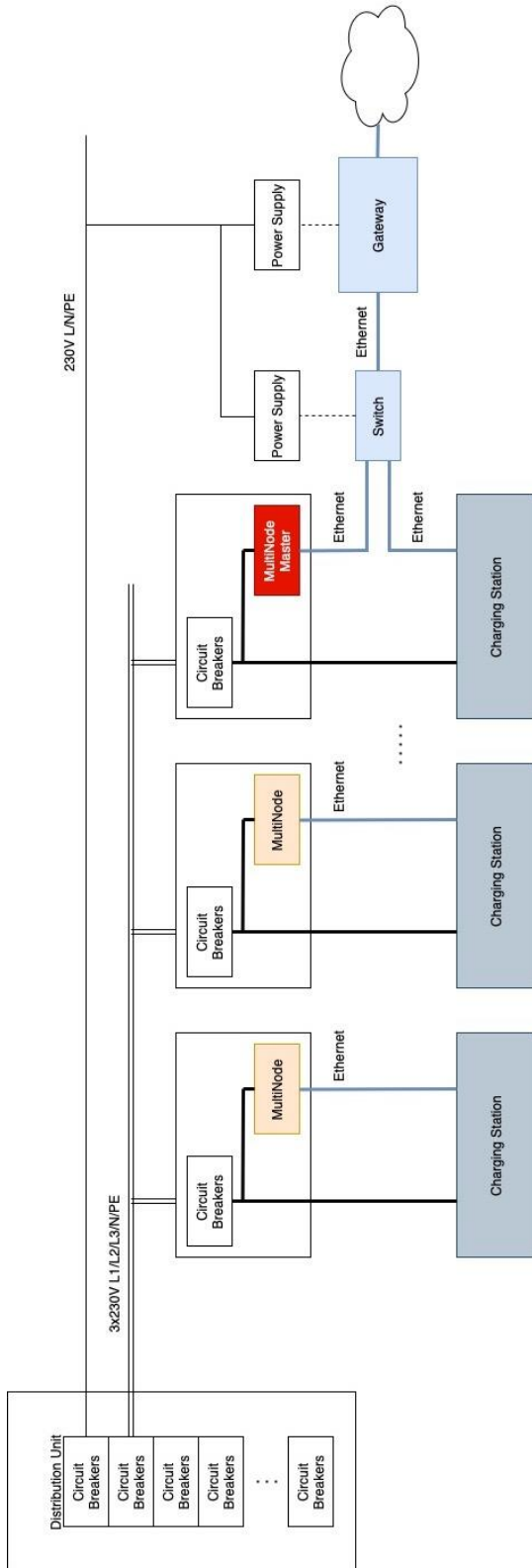

3.9.2 2: Multiple-circuit setup

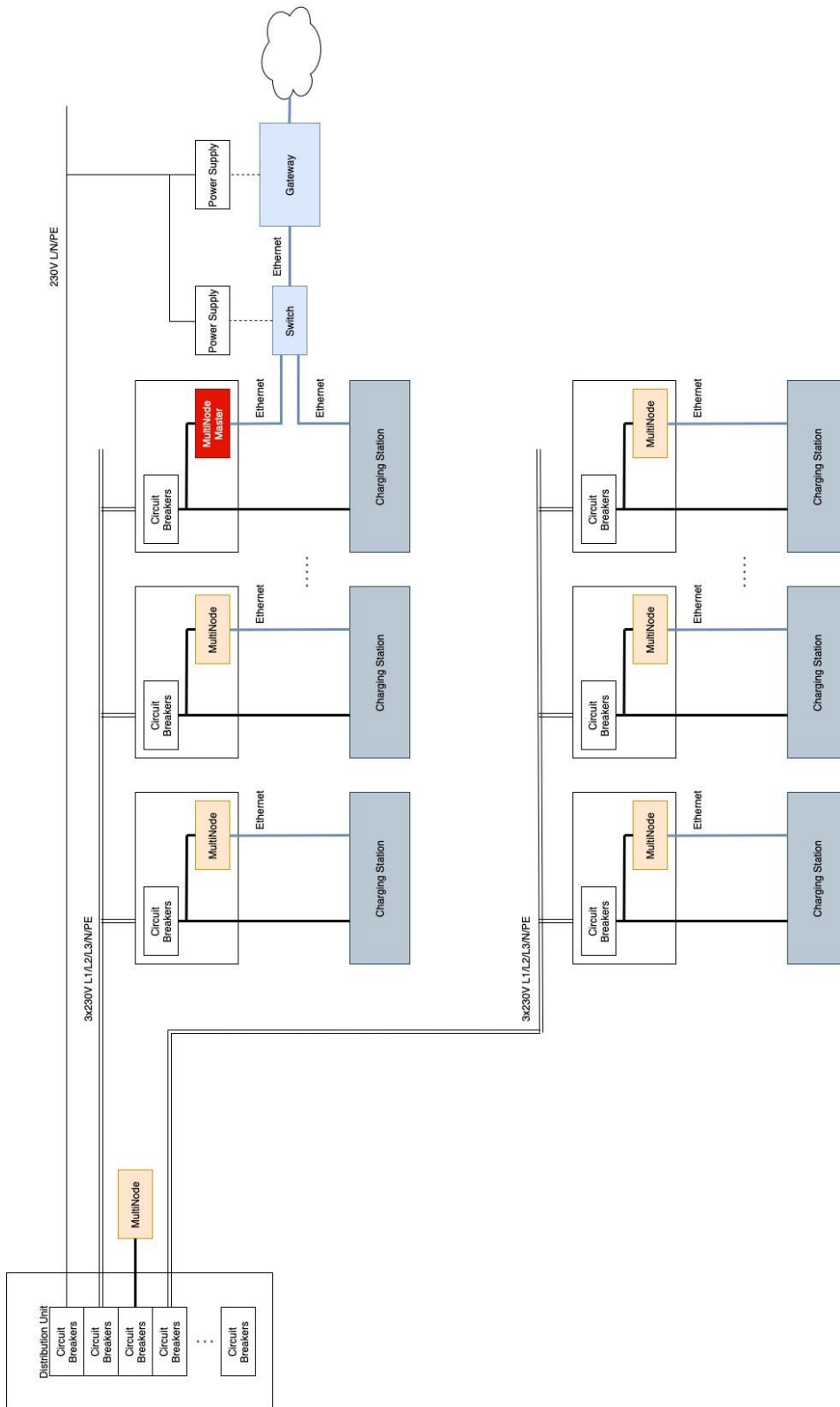

3.9.3 3: Multiple MultiNode networks

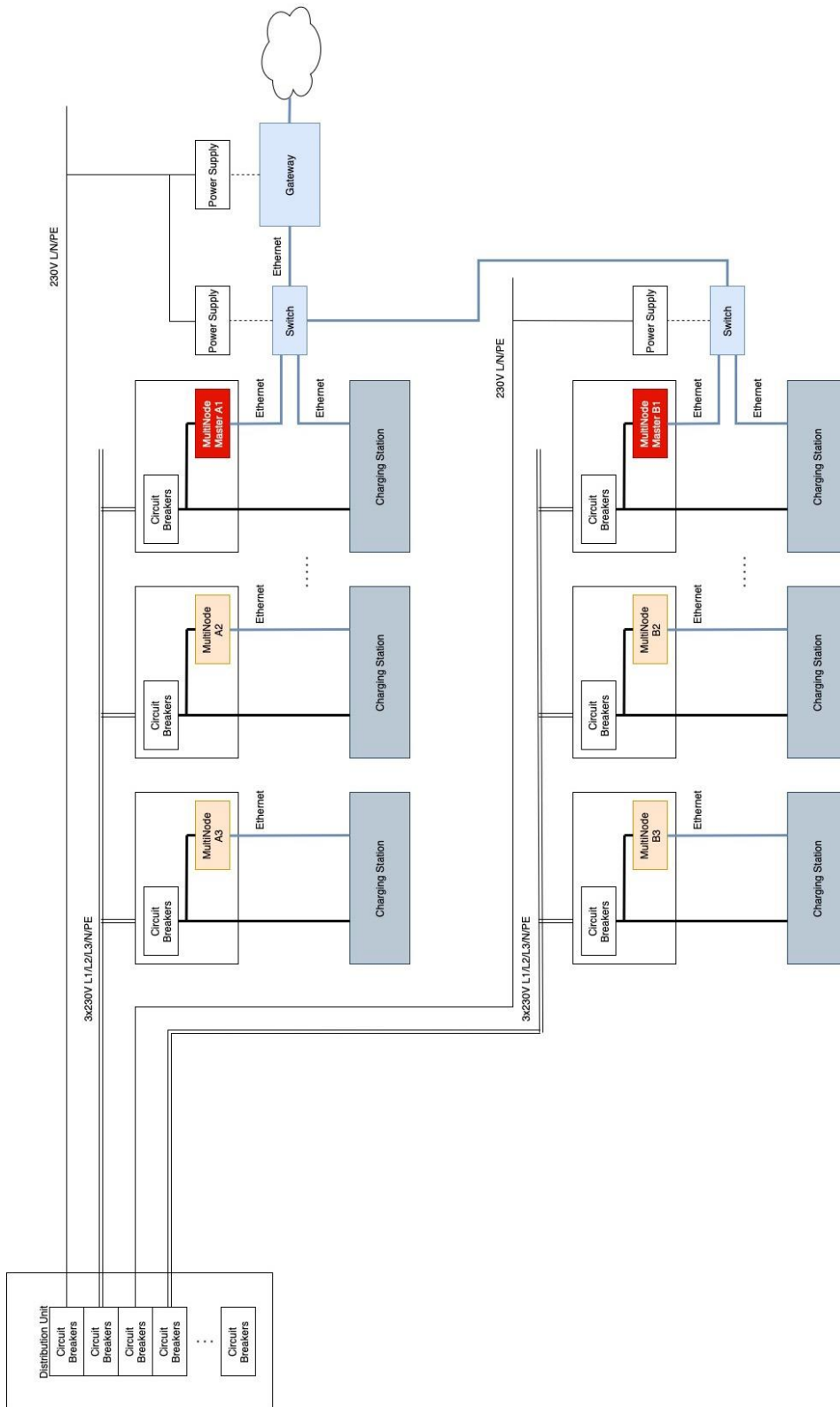

3.9.4 4: Centralized load management

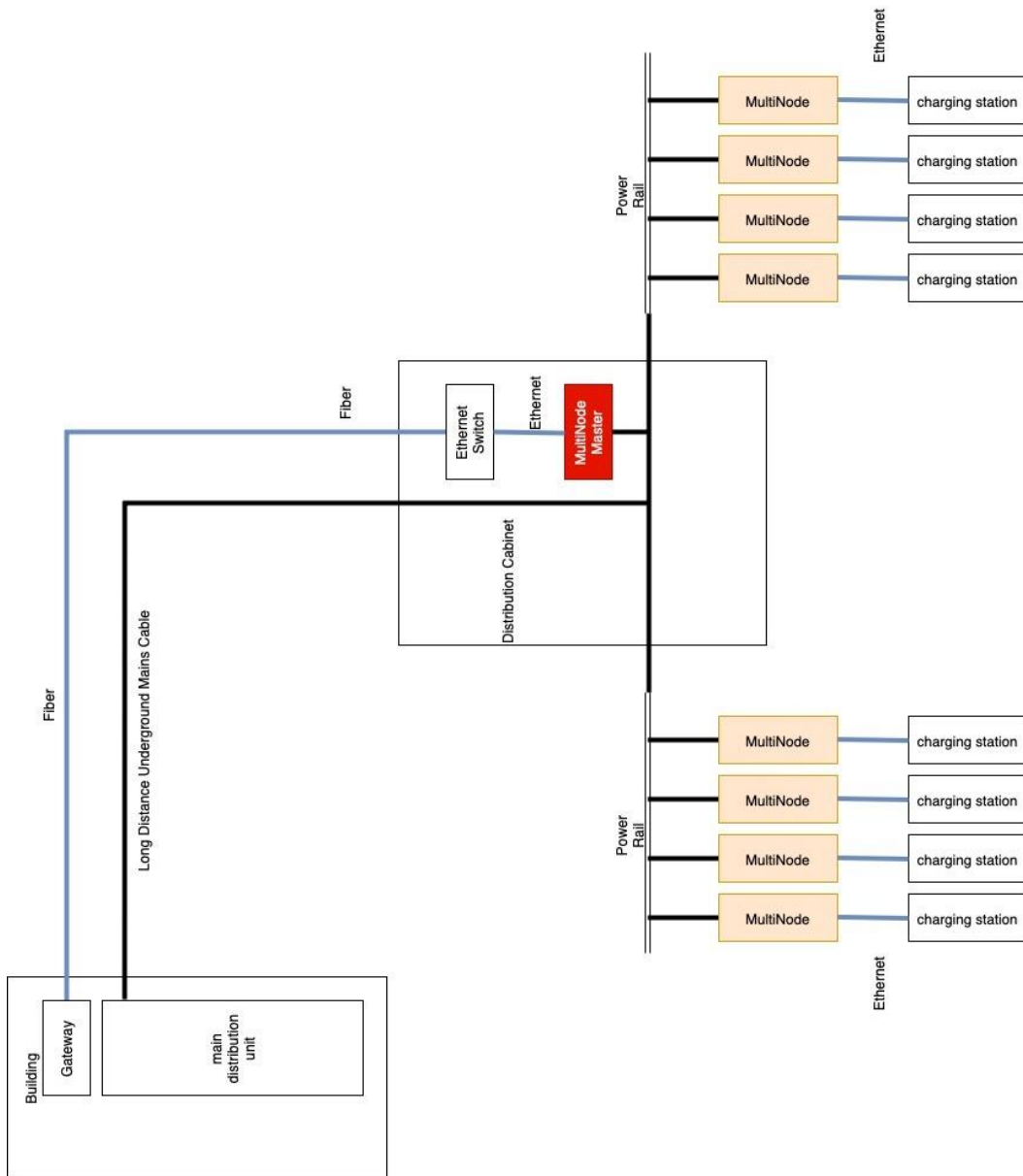

3.9.5 5: Master/slave charging stations

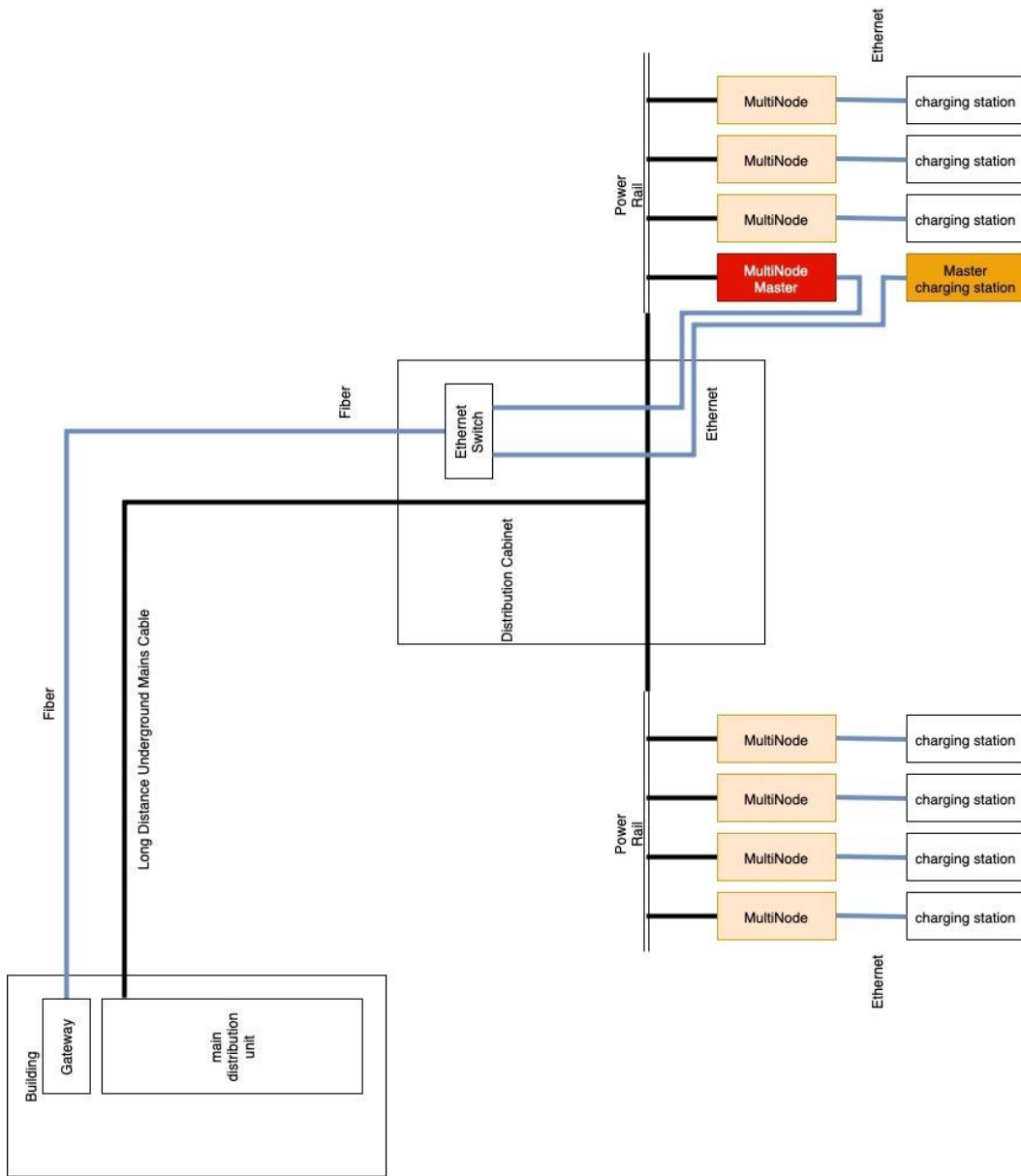

3.9.6 6: Mobile radio gateway

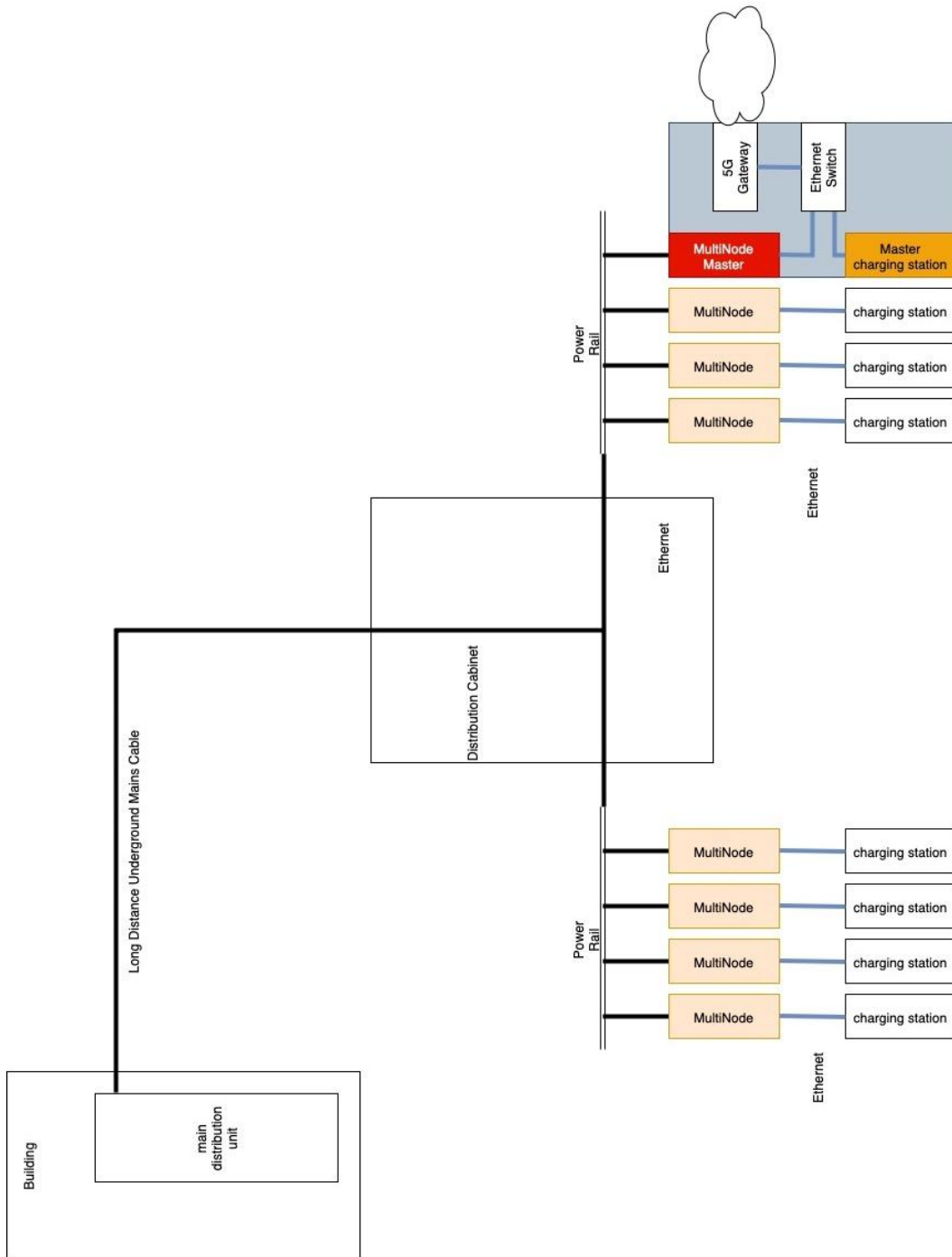

4. Electrical installation

4.1 Safety instructions

It is important to read and understand all safety and operating instructions before use. During installation, comply with all relevant national standards and directives.

Qualified electricians only



MultiNode LAN 4TE is an overvoltage category 3 device for fixed DIN-rail installation in a touch-protected or access-controlled environment. Operate only with a neutral conductor.

Installation must be carried out by a qualified electrician. Observe MOCOPA and applicable standards, e.g., German Energy Act § 49 and DIN VDE 0105-100 in Germany.

Protect the mains circuit with a circuit breaker in accordance with DIN VDE 100.

Electrical shock or fire



- Disconnect the mains supply before mounting and secure it against reconnection.
- Follow all safety regulations to prevent electric shock or arcing.
- Use an appropriate measuring instrument to verify the absence of hazardous voltage before starting work.

Electrical shock or fire from incorrect conductor cross-section or installation

Match the conductor cross-section to the circuit breaker. Ensure correct wiring of the power connection.



- Do not open the device; no user-serviceable parts inside.
- Operate only in dry environments.
- Do not insert objects into device openings.
- Keep ventilation slots clear.
- Protect from direct sunlight.
- Prevent overheating.

Replace the device if damaged, for example:

- liquid ingress or foreign objects inside,
- exposure to rain or water,
- failure to operate despite correct installation,
- visible housing damage.

4.2 Instructions for electrical installation

1. Switch off the mains supply.
2. Open the junction box or charging station intended for installation.



Electrical shock

Ensure absence of hazardous voltage.

3. Mount the MultiNode LAN 4TE on the DIN-rail with mains terminal clamps facing upward. The housing label must remain legible.
4. Connect conductors as marked on the terminals. Use $1.5 \text{ mm}^2 - 6 \text{ mm}^2$ cross-section depending on circuit breaker rating.
 - **Single-phase:** Connect neutral and L1 to N and L1.
 - **Three-phase:** Connect neutral and L1, L2, L3 to N, L1, L2, L3. The device is powered via N and L1.
 - **PE (optional):** Connect protective earth to the PE terminal.



Link quality

For best link quality, connect all three phases, neutral, and PE.

5. Connect the Ethernet port of MultiNode LAN 4TE to the Ethernet interface of the application device, e.g., gateway, switch, or charging station.



Device documentation

Record the MAC address, serial number, and installation location, e.g., floor number or parking lot number, of each node.
Both MAC address and serial number are on the housing label.
Provide this documentation to the network administrator for provisioning and tracing issues.

6. A MultiNode network requires at least two nodes.
Repeat steps 2–5 for each additional node.
7. After all devices are installed, restore mains power and close all junction boxes or charging stations.

Installation complete

Electrical installation is finished.

If nodes are not yet provisioned, continue with configuration in chapter 6 MultiNode LAN web interface.

5. Web interface

5.1 Web interface

MultiNode LAN 4TE has a built-in web server with an easy-to-use interface for network setup and management.

The screenshot displays the web interface for a MultiNode LAN 4TE device. The interface is organized into several sections:

- System Information:**
 - Name: M_P42
 - Serial number: 1807044980011155
 - MAC address: B8:BE:F4:01:DA:4F
 - Firmware version: 7.16.7.31 (2025-10-03)
 - System uptime: 0d 0h 22m
- Powerline:**
 - Local Device: Device state: Connected, but not secure; Role: Master node
 - Network: Powerline domain name: TestGrid4; Seed: 4; Online nodes: 8; Offline nodes: 2
- LAN Settings:**
 - Ethernet: Port 1: 1000 Mbps Full duplex
 - IPv4: DHCP: enabled; Address: 192.168.1.28; Netmask: 255.255.255.0; Default gateway: 192.168.1.1; Name server: 192.168.1.1
 - IPv6: Link-local address: fe80::babe:f4ff:fe01:da4f; Protocol: SLAAC; Address: fd00::babe:f4ff:fe01:da4f/64; Name server: fd00::3681:c4ff:feff:2460
- Network Overview:** A table showing network statistics for various nodes.

Name	MAC address	Upstream speed	Downstream speed
M_P42 (this device)	B8:BE:F4:01:DA:4F		
P56	00:0B:3B:7F:8C:5E	↑ 340 Mbps	↓ 140 Mbps
P62	B8:BE:F4:A4:E3:1E	↑ 285 Mbps	↓ 186 Mbps
P68	B8:BE:F4:06:98:62	↑ 349 Mbps	↓ 215 Mbps
P74	88:FC:A6:1D:35:B5	↑ 130 Mbps	↓ 147 Mbps
P86	B8:BE:F4:EC:5E:0F	↑ 153 Mbps	↓ 171 Mbps
P92	B8:BE:F4:39:AA:6E	↑ 120 Mbps	↓ 139 Mbps
P98	B8:BE:F4:3C:71:D4		
P50 (OFFLINE)	B8:BE:F4:01:00:11		
P80 (OFFLINE)	B8:BE:F4:01:00:12		

This chapter describes the web interface and is organized into the following sections:

- [Accessing the web interface](#) of MultiNode LAN 4TE
- [Creating a new MultiNode network](#)
- Using the [Overview](#) page
- Viewing and changing [Powerline](#) settings
- Using the [Network Manager](#) for managing network-wide settings and performing network-wide firmware updates

- Changing [LAN](#) settings
- Other configuration options of the product (see [System](#))

5.2 Accessing the web interface

Setting up a new network



To set up a new network, first connect your laptop to the node you want to configure as the master node via Ethernet cable.

Access to the web interface is possible via device name or IPv4 address.

5.2.1 Initial access to the web interface

Serial number

In factory-default settings, the device name is **devolo-xxxxx**, where **xxxxx** are the last 5 digits of the device's serial number. Find the serial number on the label on the front of the housing or in the installation documentation (see step 5 in [Instructions for electrical installation](#)).

To access the web interface, open a browser and enter [devolo-xxxxx.local](#) or <http://devolo-xxxxx.local>

Device name



If you rename a device, the old device name **devolo-xxxxx.local** will no longer work. You must use the new name followed by **.local** to access the device's web interface.

IPv4 address

There are several ways to get the IPv4 address of a node:

- The IPv4 address is assigned by your DHCP server (e.g., a router). You can find the address in the DHCP server's interface, which maps MAC addresses to IPv4 addresses. (The device MAC address is printed on the front label.)
- On the master node's web interface, the [Overview page](#) shows the IPv4 and MAC addresses of all regular nodes.

5.2.2 Check your firmware version

The firmware version of the device is shown at the bottom-left corner of the web interface. If the device firmware is older than version 7.16.5, see [Migrating older firmware versions](#) for next steps.

5.3 Setting up a new MultiNode network

A MultiNode network consists of exactly one master node and several regular nodes. Regular nodes automatically switch to repeater nodes.

In factory-default state, each MultiNode LAN 4TE is a regular node. You can establish the network by accessing that node you intend to set up as the master node.

After first accessing the web interface, the setup wizard starts automatically. It lets you set up this node as the master of a new network or join an existing network as a regular node.

Follow the instructions below to create a new MultiNode network. If you already have an existing network that you would like to extend with additional devices, see instructions to do so [here](#).

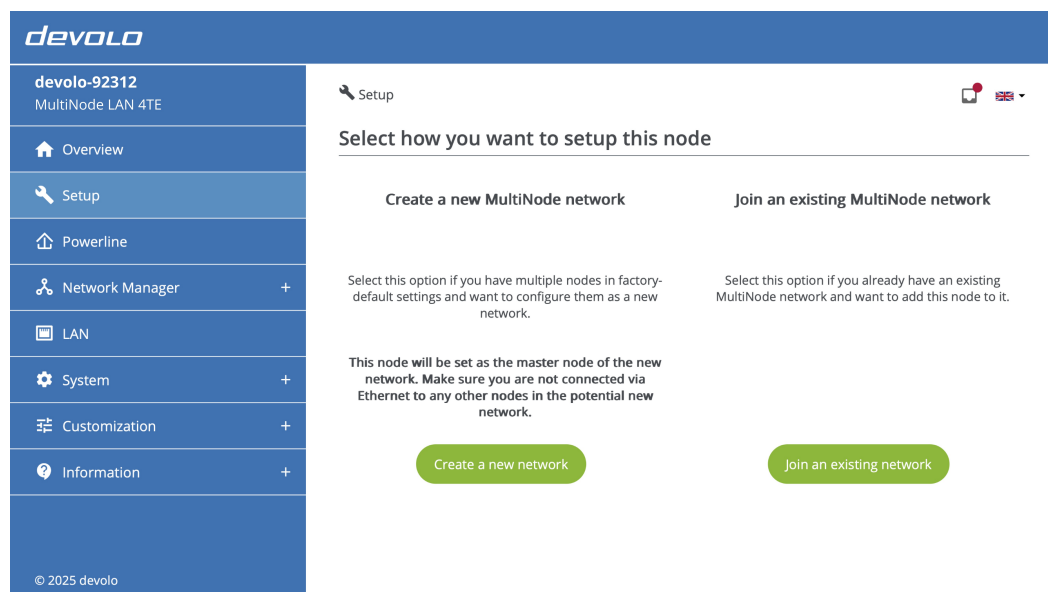

1. Click '**Create a new network**' button. This will set the current node as the master node; since other nodes are regular nodes by default, they will begin connecting to this node to form a MultiNode network.
2. On the next screen shown below, wait until all nodes have connected to the master node and then click '**Continue**'.

Setup



No web interface password set

This web interface is not secured with a password. Configure password protection to prevent unauthorized access.

Create a new network

This node is now configured as the master node. All other nodes will connect to this node to form a MultiNode network. The process may take longer if multiple nodes are involved.

Name	MAC address	Parent node	Upstream speed	Downstream speed
devolo-28142 <i>(this device)</i>	B8:BE:F4:01:DA:4F			
devolo-67189	00:0B:3B:7F:8C:5E	devolo-28142	↑ 340 Mbps	↓ 140 Mbps
devolo-82534	B8:BE:F4:A4:E3:1E	devolo-28142	↑ 285 Mbps	↓ 186 Mbps
devolo-91247	B8:BE:F4:06:98:62	devolo-28142	↑ 349 Mbps	↓ 215 Mbps
devolo-36478	88:FC:A6:1D:35:B5	devolo-28142	↑ 130 Mbps	↓ 147 Mbps
devolo-74365	B8:BE:F4:EC:5E:0F	devolo-28142	↑ 153 Mbps	↓ 171 Mbps
devolo-20691	B8:BE:F4:39:AA:6E	devolo-28142	↑ 120 Mbps	↓ 139 Mbps
devolo-49827	B8:BE:F4:3C:71:D4	devolo-20691		

Devices per page 10 1 – 8 of 8



Once all nodes are shown above, continue to the next step.
Total nodes: 8

Continue

- 3. On the next screen shown below, configure the network by entering the following details and click 'Save and apply to all nodes in the network'.

4. Finish the setup by configuring how the network handles firmware updates and new nodes added to the network.

The new network has been created successfully!

Configure how the network handles firmware updates and new nodes added to the network. You can change these settings later on the master node's web interface.

Automatic firmware updates

Allow firmware updates via devolo update server (recommended)

The master node can automatically download the latest firmware when connected to the internet, or you can upload it manually. The firmware is then ready for distribution and activation across all nodes, either automatically during a configurable update window or manually.

- Manual distribution and activation:** Once the firmware is ready, it must be distributed and activated manually.
- Automatic distribution with manual activation:** Once the firmware is ready, it will be distributed automatically during the update window but must be activated manually.
- Automatic distribution and activation (recommended):** Once the firmware is ready, it will be distributed and activated automatically during the update window.

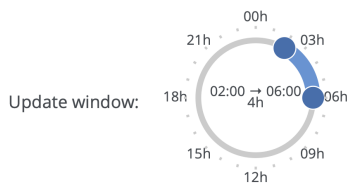

Mon Tue Wed Thu Fri Sat Sun

Approve new nodes

Select how new nodes receive admin password after joining the network.

Enable auto approval

If auto approval is enabled, new nodes with matching network settings and the default admin password will automatically receive the admin password. If auto approval is disabled, such nodes need to be manually approved in the master node's web interface to receive the admin password.

Finish setup

Powerline domain name

Enter a network name with a maximum length of 32 characters. The default network name is "HomeGrid".

Network name



Note that the network name must be unique to each Powerline network. It is highly recommended to set a meaningful network name to simplify management in the long term.

Powerline password

Password manager



It is recommended to use a password manager to store passwords.

Enter a network password with a length of 3 to 12 characters. By default, the password is empty.

Network password



Use a unique network password for each Powerline network at the site. Consider using a password manager to store passwords and other secure information for your MultiNode networks.

Seed

The default value is 0 (zero). It is recommend to use an automatic seed so that a seed from 1 to 59 that is not already used by another MultiNode network at the same site is chosen for your network.

Avoid seed 0



Do not use seed 0 in a live network, as it can affect neighboring Powerline networks.

Admin password

The admin password is 8-20 characters long and protects the management channel from unauthorized access.

Web interface password

The web interface password is 8-128 characters long and protects the web interface from unauthorized access.

5.4 Extending an existing MultiNode network

You can extend an existing MultiNode network by adding one or more new devices. New devices in factory-default state can join the network either through the setup wizard or by automatic detection.

5.4.1 Adding one or few devices

To add one or a few devices to an existing MultiNode network, use the setup wizard.

1. Take a factory-default MultiNode LAN 4TE that you would like to add to the existing network. The device can be mounted at its final location or temporarily positioned for configuration.
2. Connect an Ethernet cable to the LAN port of the device and connect the other end to your laptop.
3. Open a web browser and navigate to `devolo-xxxxxx.local` (where `xxxxxx` refers to the last five digits of the device's serial number).
4. The setup wizard starts automatically when accessing a factory-default device.

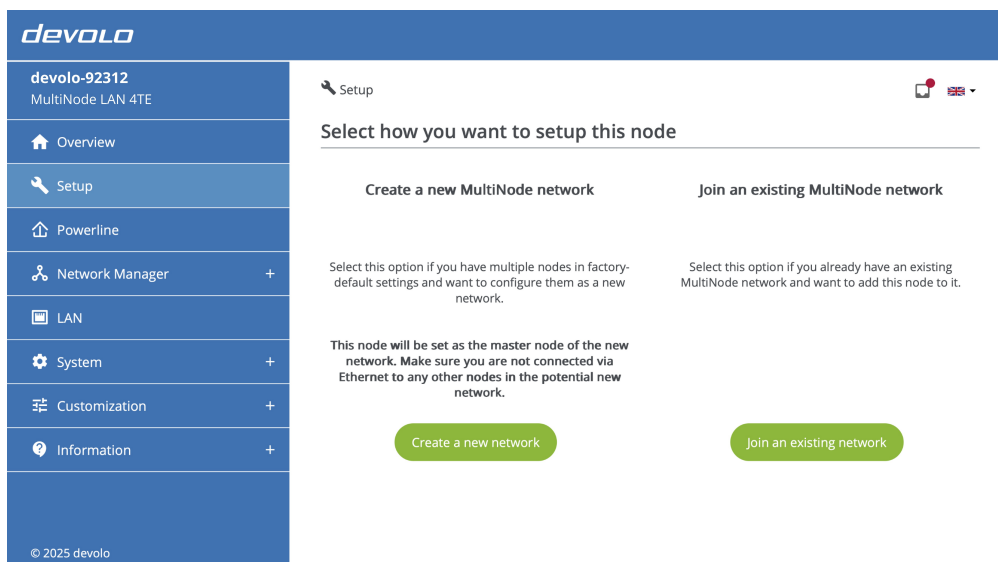

5. Click 'Join an existing network'.
6. The device will scan for available networks and display them on the next screen.

The screenshot shows the 'Join an existing network' page in the devolo web interface. The left sidebar contains navigation options: Overview, Setup, Powerline, LAN, System, Customization, and Information. The main content area is titled 'Join an existing network' and features a search bar for existing networks. A table lists available networks, with 'ParkingL2Berlin' selected. Below the table, there are input fields for 'Powerline domain name' (set to 'HomeGrid'), 'Powerline password', 'Seed' (set to '0'), 'Node name (optional)' (set to 'devolo-92312'), 'Admin password (optional)', and 'Web interface password (optional)'. A 'Join this network' button is at the bottom.

devolo-92312
MultiNode LAN 4TE

Setup

Join an existing network

Search for existing networks

Network name	Seed
<input type="radio"/> ParkingL2Berlin	56

Powerline domain name:
HomeGrid

Powerline password:
Password

Seed:
0

Index 0 should only be used during installation and not during normal operation because it can cause conflicts with new domain installations.

Node name (optional)

Node name:
devolo-92312
Max. 16 characters

Admin password (optional)

Enter the admin password:
Password

Web interface password (optional)

Enter the web interface password:
Password

Join this network

© 2025 devolo

- Select the network you want to join and enter the required credentials. This will automatically set the powerline domain name and seed.
 - Powerline password:** Required for joining the network
 - Admin password:** Optional, depending on auto-approval settings
 - Web interface password:** Optional, for accessing the device's web interface

Auto approval



If auto approval is enabled on the master node's web interface, the admin password is not required. If auto approval is disabled, you can open the master node's web interface and manually approve the new node instead of entering the admin password.

- Click 'Join this network' to complete the process.
- The device will connect to the selected network and become a regular node.

Network discovery



The device automatically scans for available MultiNode networks on the same electrical circuit. Ensure the new device is connected to the same power grid as the existing network.

5.4.2 Adding several devices

To add multiple devices simultaneously to an existing MultiNode network, reset the powerline settings of the existing network to factory defaults, mount the new devices, and set up a larger network.

Downtime



Resetting the existing MultiNode network's powerline settings to factory defaults will result in downtime for application devices connected to MultiNode devices.

1. Mount and connect all new devices to the same electrical circuit as the existing network.
2. Power on all new devices without connecting via Ethernet.
3. Open the web interface of the existing network's master node. Navigate to **Network Manager > Settings** and click '**Reset network settings of all nodes to factory defaults**'.

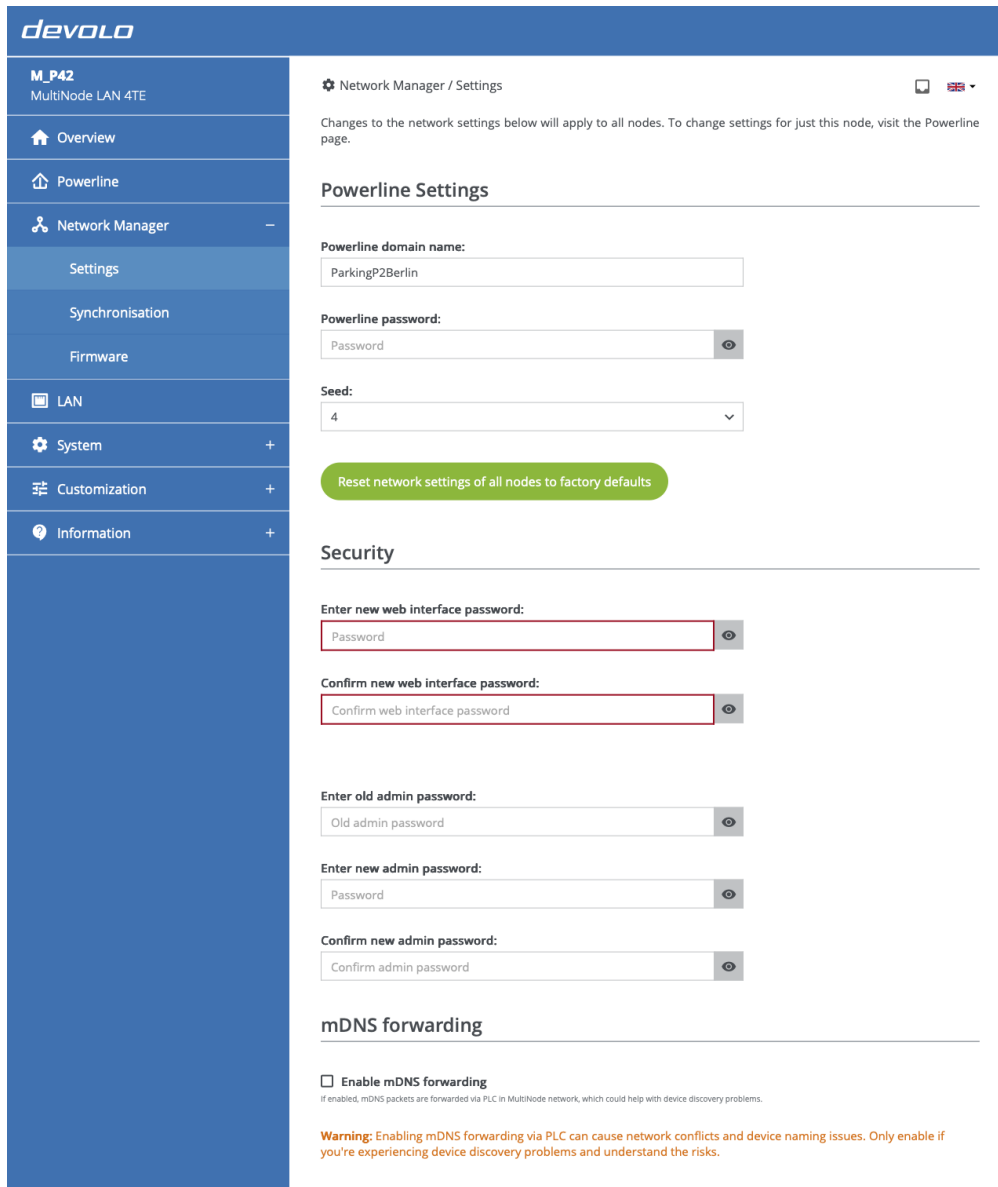

devolo

M_P42
MultiNode LAN 4TE

Overview

Powerline

Network Manager

Settings

Synchronisation

Firmware

LAN

System +

Customization +

Information +

Network Manager / Settings

Changes to the network settings below will apply to all nodes. To change settings for just this node, visit the Powerline page.

Powerline Settings

Powerline domain name:
ParkingP2Berlin

Powerline password:
Password

Seed:
4

Reset network settings of all nodes to factory defaults

Security

Enter new web interface password:
Password

Confirm new web interface password:
Confirm web interface password

Enter old admin password:
Old admin password

Enter new admin password:
Password

Confirm new admin password:
Confirm admin password

mDNS forwarding

Enable mDNS forwarding
If enabled, mDNS packets are forwarded via PLC in MultiNode network, which could help with device discovery problems.

Warning: Enabling mDNS forwarding via PLC can cause network conflicts and device naming issues. Only enable if you're experiencing device discovery problems and understand the risks.

- Follow the instructions for [setting up a new MultiNode network](#). The new devices will automatically join the master node during network formation.
- Access the master node's web interface to verify that all devices (existing and new) appear in the network overview.

Same electrical circuit



Ensure all extension devices are connected to the same mains circuit as the existing network for automatic discovery and connection.

5.4.3 Verification

After adding new devices to the network:

- Access the master node's web interface and navigate to the [Overview page](#) to confirm all new devices are listed.
- Verify that each device shows an active connection status.
- Optionally, rename the new devices to identify them more easily in the network overview.

5.5 Overview

devolo

M_P42
MultiNode LAN 4TE

- Overview
- Powerline
- Network Manager
- LAN
- System
- Customization
- Information

Overview

System

Information

- Name: M_P42
- Serial number: 1807044980011155
- MAC address: B8:BE:F4:01:DA:4F
- Firmware version: 7.16.7.31 (2025-10-03)
- System uptime: 0d 0h 22m

LAN

Ethernet

- Port 1: 1000 Mbps Full duplex

IPv4

- DHCP: enabled
- Address: 192.168.1.28
- Netmask: 255.255.255.0
- Default gateway: 192.168.1.1
- Name server: 192.168.1.1

IPv6

- Link-local address: fe80::babe:f4ff:fe01:da4f
- Protocol: SLAAC
- Address: fd00::babe:f4ff:fe01:da4f/64
- Name server: fd00::3681:c4ff:feff:2460

Powerline

Local Device

- Device state: ● Connected, but not secure
- Role: Master node

Network

- Powerline domain name: TestGrid4
- Seed: 4
- Online nodes: 8
- Offline nodes: 2

Network overview

Table | Topology

Name	MAC address	Upstream speed	Downstream speed
M_P42 (this device)	B8:BE:F4:01:DA:4F		
P56	00:0B:3B:7F:8C:5E	↑ 340 Mbps	↓ 140 Mbps
P62	B8:BE:F4:A4:E3:1E	↑ 285 Mbps	↓ 186 Mbps
P68	B8:BE:F4:06:98:62	↑ 349 Mbps	↓ 215 Mbps
P74	88:FC:A6:1D:35:B5	↑ 130 Mbps	↓ 147 Mbps
P86	B8:BE:F4:EC:5E:0F	↑ 153 Mbps	↓ 171 Mbps
P92	B8:BE:F4:39:AA:6E	↑ 120 Mbps	↓ 139 Mbps
P98	B8:BE:F4:3C:71:D4		
P50 OFFLINE	B8:BE:F4:01:00:11		
P80 OFFLINE	B8:BE:F4:01:00:12		

The Overview page provides detailed information about the current node and, in the case of master node, the entire MultiNode network. On a regular node's web interface, available details are limited due to [peer-to-peer isolation](#). Most of the information shown on this page is comprehensive and largely self-explanatory.

5.5.1 Table & topology views

Web interfaces of master vs. regular nodes



On the master node's web interface, the network overview table lists all nodes in the network. On a regular node's web interface, only a sub-network overview is available due to peer-to-peer isolation. The **Name** column in the table includes links to open the web interface of other nodes in the network.

The Overview page offers two ways to view the network: **table view** and **topology view**. Both views display the same number of nodes, include offline nodes, and allow you to rename nodes.

The **table view** shows all nodes in a flat list. Columns can be sorted, and pagination helps reduce visual clutter when many nodes are present.

Network overview

Table | Topology

Show only offline nodes











Name	MAC address	Parent node	Upstream speed	Downstream speed
M_P42 <i>(this device)</i>	B8:BE:F4:01:DA:4F			
P56	00:0B:3B:7F:8C:5E	M_P42	↑ 340 Mbps	↓ 140 Mbps
P62	B8:BE:F4:A4:E3:1E	M_P42	↑ 285 Mbps	↓ 186 Mbps
P68	B8:BE:F4:06:98:62	M_P42	↑ 349 Mbps	↓ 215 Mbps
P74	88:FC:A6:1D:35:B5	M_P42	↑ 130 Mbps	↓ 147 Mbps
P86	B8:BE:F4:EC:5E:0F	M_P42	↑ 153 Mbps	↓ 171 Mbps
P92	B8:BE:F4:39:AA:6E	M_P42	↑ 120 Mbps	↓ 139 Mbps
P98	B8:BE:F4:3C:71:D4	P92		
P50 OFFLINE	B8:BE:F4:01:00:11	M_P42		
P80 OFFLINE	B8:BE:F4:01:00:12	M_P42		

Devices per page 10 1 - 10 of 10

The **topology view** uses indentation to represent the hierarchical structure of the network.

Network overview

Table Topology

Name		MAC address	Upstream speed	Downstream speed
M_P42 <i>(this device)</i>		B8:BE:F4:01:DA:4F		
— P56		00:0B:3B:7F:8C:5E	↑ 340 Mbps	↓ 140 Mbps
— P62		B8:BE:F4:A4:E3:1E	↑ 285 Mbps	↓ 186 Mbps
— P68		B8:BE:F4:06:98:62	↑ 349 Mbps	↓ 215 Mbps
— P74		88:FC:A6:1D:35:B5	↑ 130 Mbps	↓ 147 Mbps
— P86		B8:BE:F4:EC:5E:0F	↑ 153 Mbps	↓ 171 Mbps
— P92		B8:BE:F4:39:AA:6E	↑ 120 Mbps	↓ 139 Mbps
└─ P98		B8:BE:F4:3C:71:D4		
— P50 OFFLINE		B8:BE:F4:01:00:11		
— P80 OFFLINE		B8:BE:F4:01:00:12		

5.6 Powerline

Use the Powerline page to view and edit these properties of the current node:

devolo

M1
Grid 2 LAN

Overview

Powerline

Network Manager +

LAN

System +

Information +

Powerline

Node

Role:
Master node

When you set this node as master, it will first check for another master node with the same seed. If a master node already exists, this node will remain a regular node.

Check for an existing master node on every reboot

Powerline Network

Use the Network Manager on the master node's web interface to modify the network settings for the entire network. Any changes to the network settings below will be applied only to this node.

Go to Network Manager of the master node

Powerline domain name:
ParkingP2Berlin

Powerline password:
Password

Seed:
30

Reset network settings to factory defaults

Node

Use the dropdown to set the node's role. All nodes are regular nodes by default, and each network has exactly one master node.

- When a regular node is set as the master node, the node first checks if another master with the same seed exists. If one is found, the node **stays a regular node**.
- When a master node is set as the regular node, the existing MultiNode network is dissolved. To form a network again, one of the regular nodes needs to be set as the master.

Powerline network

- To change Powerline parameters (domain name, password, and seed) for all nodes, click **Go to Network Manager of the master node** to open the [Network Manager](#).
- To change Powerline parameters only for this local node, enter the target network's settings (domain name, password, and seed). This is useful if you have an existing network and want to have current node join that network.

Network might take a while to be formed



Depending on network size, it may take time for nodes to connect together to form a network. The network LED  shows the connection status.

Reset network settings to factory default

- To remove a MultiNode LAN 4TE from your network and restore to factory defaults, click **Reset network settings to factory default**. All configured settings will be lost.
- Wait until the network LED  flashes red.
- To set up a new MultiNode LAN 4TE, see [Setting up a new MultiNode network](#).

5.7 Network Manager

The Network Manager is available only on the master node's web interface. Use it to configure network-wide settings and updates for every node in the MultiNode network. The page is organised into three subpages: Security, Synchronisation, and Firmware.

5.7.1 Network Manager → Settings

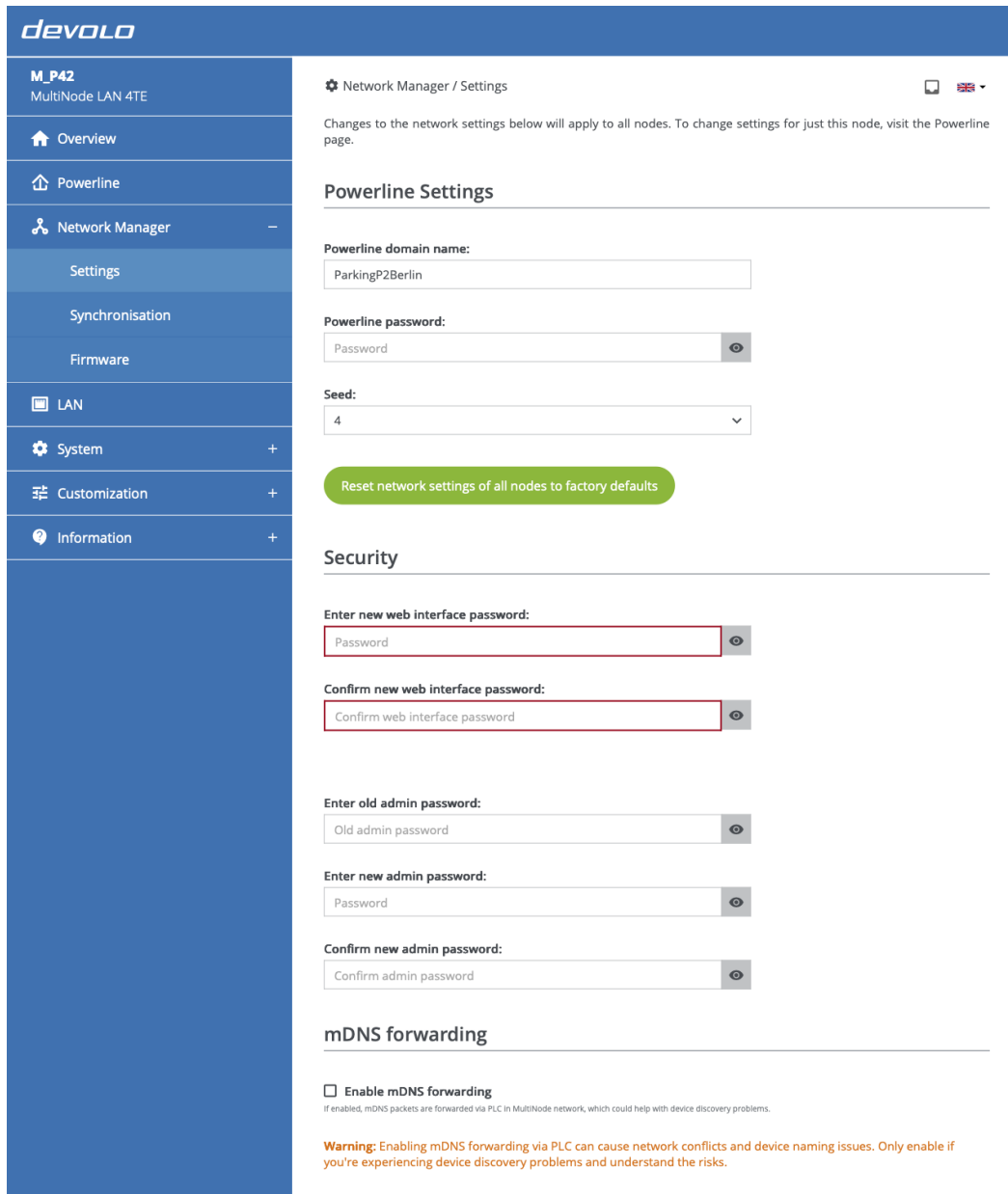

devolo

M_P42
MultiNode LAN 4TE

Overview

Powerline

Network Manager

Settings

Synchronisation

Firmware

LAN

System

Customization

Information

Network Manager / Settings

Changes to the network settings below will apply to all nodes. To change settings for just this node, visit the Powerline page.

Powerline Settings

Powerline domain name:

Powerline password:

Seed:

Reset network settings of all nodes to factory defaults

Security

Enter new web interface password:

Confirm new web interface password:

Enter old admin password:

Enter new admin password:

Confirm new admin password:

mDNS forwarding

Enable mDNS forwarding
If enabled, mDNS packets are forwarded via PLC in MultiNode network, which could help with device discovery problems.

Warning: Enabling mDNS forwarding via PLC can cause network conflicts and device naming issues. Only enable if you're experiencing device discovery problems and understand the risks.

Use the Settings subpage to view and manage network-wide settings. You can configure:

- [Powerline settings: domain name, domain password, and seed](#)
- [Web interface password](#)
- [Admin password](#)

- **mDNS forwarding:** Enabling mDNS forwarding could help with device discovery issues in certain networks. As this can cause device naming issues, it is recommended to enable mDNS forwarding only if you are experiencing device discovery problems.

Save your changes to apply them across the network immediately.

5.7.2 Network Manager → Synchronisation

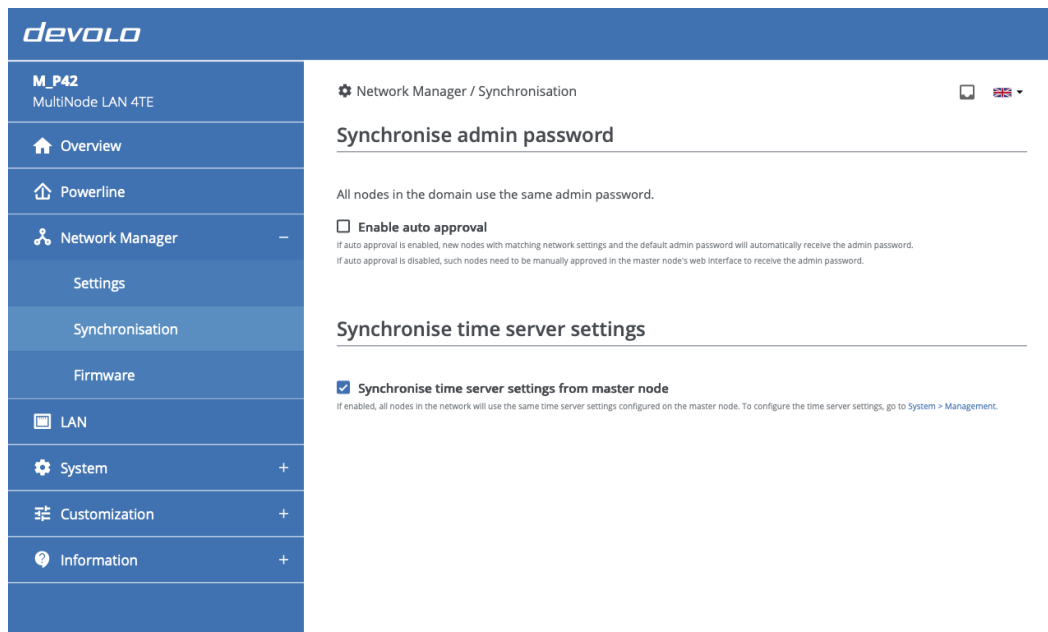

The screenshot shows the web interface for a devolo MultiNode LAN 4TE. The left sidebar contains a navigation menu with items: Overview, Powerline, Network Manager (selected), Settings, Synchronisation, Firmware, LAN, System, Customization, and Information. The main content area is titled 'Network Manager / Synchronisation' and features two sections: 'Synchronise admin password' and 'Synchronise time server settings'. The 'Synchronise admin password' section includes a checkbox for 'Enable auto approval' and explanatory text. The 'Synchronise time server settings' section includes a checked checkbox for 'Synchronise time server settings from master node' and explanatory text.

Synchronise admin password

When you introduce a new node to an existing MultiNode network, it needs the correct powerline settings and the current admin password. Configure **Auto approval** to let the master node provide the admin password to any node that joins with matching powerline settings.

Auto approval



Auto approval works only when the new node still uses the default admin password. If you have already changed the password on that node, the admin credentials will not sync from the master node.

Synchronise time server settings

When synchronisation is enabled, the time server settings from the master node are applied to all nodes in the network. Keeping this enabled is recommended.

5.7.3 Network Manager → Firmware

devolo-28
MultiNode LAN 4TE

Network Manager / Firmware

Security risk: no password is set to protect this web interface.
Go to password settings.

This page updates firmware on all nodes in the network. To update only this node, go to System > Firmware.

Firmware update

Allow firmware updates via devolo update server (recommended)

Installed firmware: (1 nodes)
Ready for update: None

- Step 1: Select firmware for update**
Click the button below to select a firmware file for update. Download the latest MultiNode firmware on the product's downloads page.
[Browse for firmware file ...](#)
[Upload](#)
- Step 2: Distribute firmware**
- Step 3: Activate firmware**

[Show details](#)

Scheduled update

The master node can automatically download the latest firmware when connected to the internet, or you can upload it manually. The firmware is then ready for distribution and activation across all nodes, either automatically during a configurable update window or manually.

- Manual distribution and activation:** Once the firmware is ready, it must be distributed and activated manually.
- Automatic distribution with manual activation:** Once the firmware is ready, it will be distributed automatically during the update window but must be activated manually.
- Automatic distribution and activation (recommended):** Once the firmware is ready, it will be distributed and activated automatically during the update window.

Update window:

Mon Tue Wed Thu Fri Sat Sun

© 2025 devolo

Use the Firmware subpage to distribute and activate firmware across the network. The update workflow consists of three steps:

- 1. Select firmware:** Upload a file from your computer or let MultiNode LAN 4TE download the latest version from the devolo update server. This step stores the firmware on the master node without changing the running version.
- 2. Distribute:** Copy the firmware from the master node to every regular node. Distribution does not trigger a reboot.
- 3. Activate:** Reboot all nodes to activate the new firmware.

You can also automate firmware management. MultiNode LAN 4TE can automatic download updates from the devolo update server and, together with a defined update window, run distribution and activation without manual intervention.

Firmware update duration

Large networks with more than 50 nodes can take over one hour to update.

5.8 LAN

Use the LAN page to check link status and manage IP settings for MultiNode LAN 4TE.

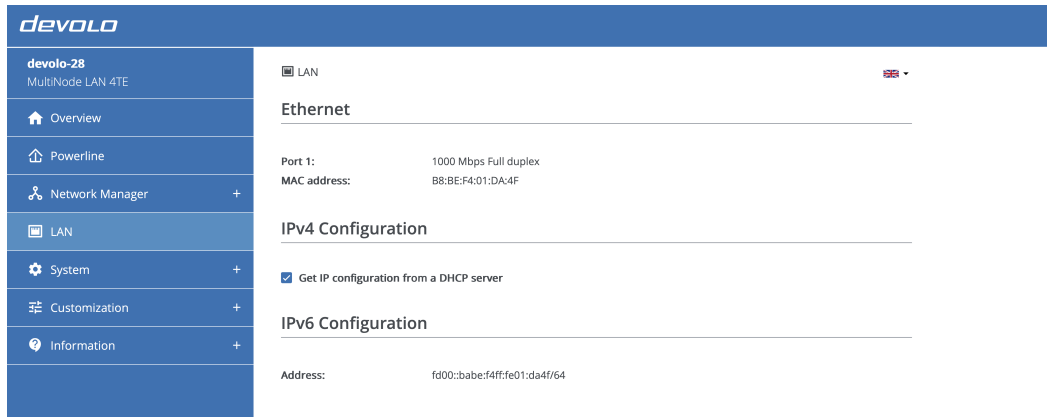

Ethernet

The Ethernet section shows whether the port is connected, the negotiated speed and duplex mode (for example, "1000 Mbps full duplex"), and the device MAC address.

IPv4 configuration

By default, the device requests an address from a DHCP server. Leave **Get IP configuration from a DHCP server** enabled when a DHCP server is available so the device always receives its settings automatically.

To use a static configuration, disable the DHCP option and enter the IPv4 address, subnet mask, default gateway, and name server. Click the disk icon to save, then restart the device to apply the new settings.

IPv6 configuration

This section lists the global IPv6 address that the device uses for Internet connectivity.

5.9 System

Use the System page to manage settings that apply to the local MultiNode LAN 4TE.

5.9.1 System → Status

⚙ System / Status



Date and Time

Local time:	28.08.2024 13:45
Last successful sync:	Not synchronized
Time Server 1:	ptbtime1.ptb.de
Time Server 2:	ptbtime2.ptb.de
Time Server 3:	ptbtime3.ptb.de

MAC address

Ethernet:	B8:BE:F4:01:DA:4F
-----------	-------------------

The Status subpage shows the current date and time, the configured NTP servers, and the device MAC address.

5.9.2 System → Management

System / Management



System Information

Node name:

Max. 16 characters

Hostname:

Your device will be shown on your home gateway under this name.

Web interface password

Enter new web interface password:



Confirm new web interface password:



Admin password

Enter old admin password:



Enter new admin password:



Confirm new admin password:



Identify Device

Activate this button to identify this device. The Powerline LED will flash in white for two minutes.

Identify Device

Node name

Rename the device to make it easier to identify. Use a descriptive name that reflects the installation location, such as "P42".

Web interface and admin passwords

Set the local web interface and admin passwords for this device.

Network-wide passwords



To use the same credentials across the network, update them from [Network Manager → Security](#) on the master node.

Identify device

Click **Identify** to flash the white PLC LED for two minutes. This can help locate the device in the field.

LED

You can disable the LED. This applies to normal operation, e.g. when the device is connected to a Powerline network or has entered standby mode. The LED still indicates ongoing pairing or connection problems.

LED enabled

Time Zone

Europe/Berlin ▼

Time Server (NTP)

The switch between summer and winter time is done automatically by the time server. No manual settings are needed.

Without a time server available all time based services will not work, including firmware updates!

Get time server configuration from the DHCP server.

The change will only take effect after the next restart.

+ Add

ID	Time Server
Max. number of Time Servers: 5.	
1	ptbtime1.ptb.de
2	ptbtime2.ptb.de
3	ptbtime3.ptb.de

Data collection

devolo collects anonymous data about the MultiNode network to improve the product. You may disable data collection below if you prefer not to participate.

Enable data collection (recommended)

LED

Disable the LEDs during normal operation if needed. Error conditions still trigger flashing LEDs, even when the **LED enabled** option is off.

Time zone

Select the appropriate time zone (for example, Europe/Berlin).

Time server (NTP)

Review or edit the list of NTP servers used to synchronise the clock. Without a valid time set, scheduled tasks such as firmware updates may fail.

5.9.3 System → Certificate

⚙ System / Certificate 

To upload a custom certificate, two options are available:

1. **Upload a certificate and private key** in PKCS10 format.
2. **Upload a certificate** generated from a Certificate Signing Request (CSR).

Upload certificate and private key

Upload a certificate and ECC private key in PKCS10 format. The uploaded certificate will take effect after two seconds.

Browse certificate...

No certificate selected.

Upload

Upload certificate generated from a CSR

Click the button below to generate and download a Certificate Signing Request (CSR). Use the CSR to obtain a certificate, then upload the certificate without including the private key.

The uploaded certificate will take effect after two seconds.

Generate and download CSR

Browse certificate...

No certificate selected.

Upload

Details of the current certificate

Fingerprint:	F8:3E:67:B0:3F:0C:CC:BF:A0:9C:46:30:8A:D0:2B:D8:52:CE:81:27
Subject:	C=DE, L=Aachen, O=devolo, CN=devolo-00819
Issuer:	C=DE, L=Aachen, O=devolo, CN=devolo-00819
Serial number:	1291D3F40B3548806BDBA2F040C4AB3C2A055DF
Not before:	09.10.2024 00:00
Not after:	09.10.2044 23:59
Public key info:	Elliptic Curve P-256

Upload a custom certificate bundle in PEM format containing both the private key (RSA or ECC) and certificate. The change takes effect within a few seconds.

5.9.4 System → Configuration

⚙ System / Configuration



Factory Settings

When you activate this button, all device settings will be deleted and the configuration will be reset to factory defaults.

Factory reset

Reboot

When you activate this button, the device will be restarted.

Reboot

Factory settings

Click **Factory reset** to restore default settings. The device leaves the existing network; if it is the master node, the network dissolves.

Reboot

Click **Reboot** to restart the device without changing the configuration. After the reboot, the browser redirects to the [Overview page](#).

5.9.5 System → Firmware

⚙ System / Firmware



This page updates firmware on this node only. To update all nodes, go to Network Manager > Firmware page on the master node's web interface.

Current Firmware

Firmware version: 7.16.6.33 (2025-07-03)

Firmware update

Please review the [release notes](#) before updating the firmware.

Click the button below to select a firmware file for update. Download the latest MultiNode firmware on the product's [downloads page](#).

Browse for firmware file ...

Upload

Use this subpage to update the firmware on the current device. Automatic downloads are not available here, so download the newest firmware from the [product downloads page](#) before starting.

To update the firmware:

1. Download the latest firmware file from the product downloads page.
2. Click **Browse for firmware file...** and select the file.
3. Click **Upload** to install it. The device restarts automatically and returns to the Overview page.

Avoid interrupting the update. A progress bar shows the status.

6. Support & Warranty

6.1 Contact us

Find more information about devolo MultiNode LAN on our [website](#). For questions or technical issues, contact support:

- **E-mail:** support@devolo.com or
- **Phone:** Our hotline numbers can be found on our [website](#).

6.2 Warranty

If your device is defective during installation or within the warranty period, contact us. We will handle the repair or warranty claim. See the complete warranty conditions on our [website](#).